

HALOGEN FREE

REVISIONS			
REV	DESCRIPTION	DWN	DATE
K	UPDATE DIM.	KELLY	2018-09-10
L	UPDATE DATE CODE	KELLY	2018-10-17

NOTES:

- MATERIAL:
  - OUTSIDE SHELL: STAINLESS STEEL.
  - INNER SHELL: STAINLESS STEEL.
  - SIGNAL: STAINLESS STEEL.
  - RFI PAD: STAINLESS STEEL.
  - HOUSING: THERMOPLASTIC,HIGH TEMP,UL94V-0.
  - TEMPERARL: COPPER ALLOY.
- PLATING:
  - SEE NOTES 5
- ELECTRICAL CHARACTERISTICS:
  - CURRENT RATING: 3.0 A  
VOLTAGE RATING: 5.0 V
  - LLCR: VBUS& GND PINS: 40mΩ/PIN MAX  
OTHER PINS : 40mΩ/PIN MAX  
LLCR MAX. CHANGE OF ALL PINS: 10mΩ
  - INSULATION RESISTANCE: 100MΩ MIN.
- MECHANICAL CHARACTERISTICS:
  - INSERTION FORCE: 0.5~2.0kg.
  - WITHDRAWAL FORCE: 0.8~2.0kg.(INITIAL) 0.6~2.0kg.(AFTER LIFE TEST)
- P/N : UTC-011-1R24HX

PLATING OF CONTACT AREA  
G: GOLD FLASH  
6: 30u" Au

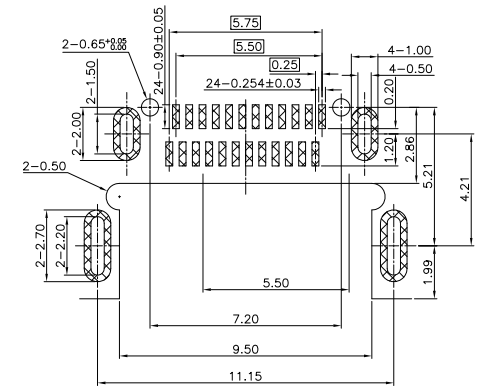
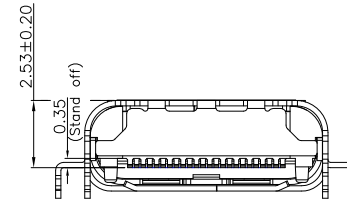
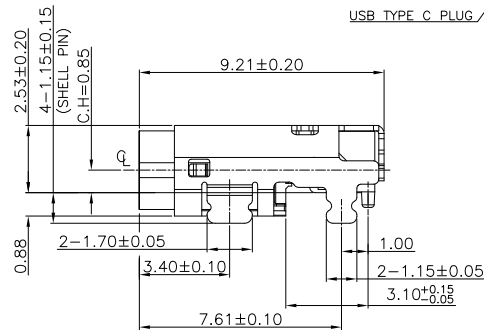
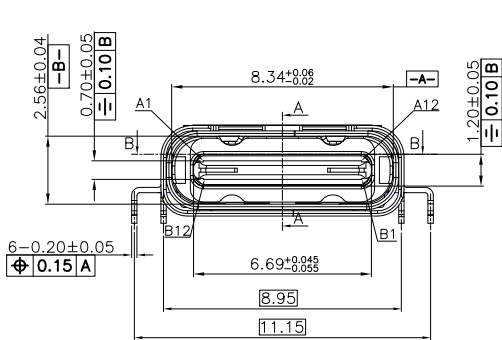
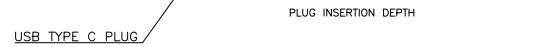
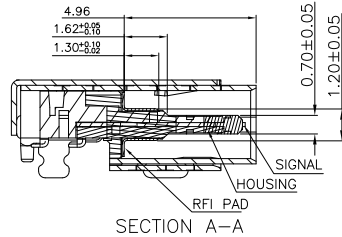
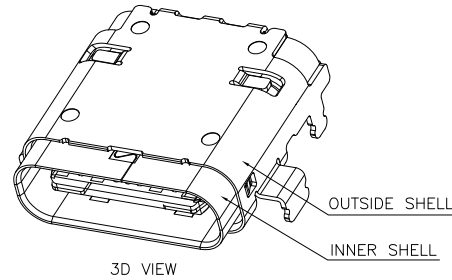
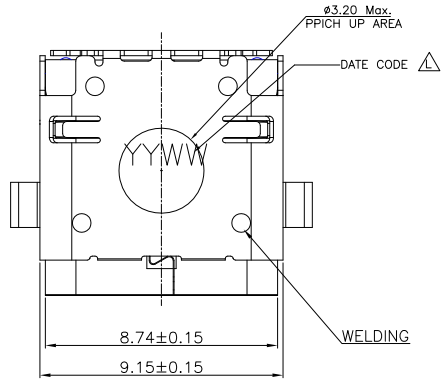

RECOMMENDED PCB LAYOUT(TOP VIEW)  
(TOLERANCE=±0.05mm)

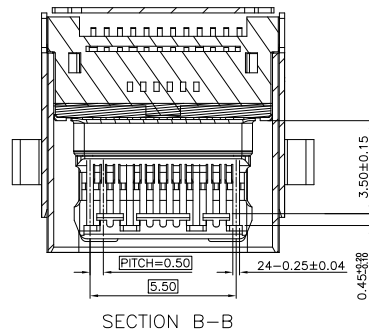
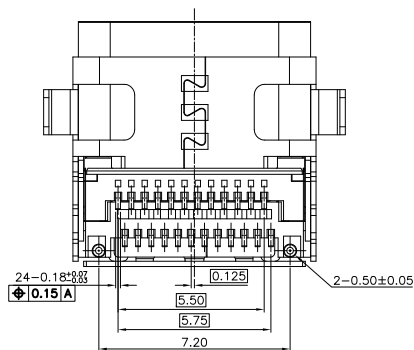

GENERAL TOLERANCES (OTHERWISE SPECIFIED)	SCALE NONE	DESIGN UNITS MILIMETER	
4 PLS ±	DRAWN BY KELLY	DATE 2018-10-17	
3 PLS ± 0.15	CHECKED BY	DATE	PART NO. UTC-011-1R24HX
2 PLS ± 0.25	APPROVED BY	DATE	
1 PLS ± 0.35	DRAWING NO. SD-UTC011-001		DWG REV. L
ANGLES ± °			SHEET NO. 1 OF 1
QUALITY SYMBOLS ▽=0			SIZE
THIS DRAWING CONTAINS INFORMATION THAT IS PROPRIETARY TO VITECK CORP., LTD AND SHOULD NOT BE USED WITHOUT WRITTEN PERMISSION			THIRD ANGLE PROJECTION

7

6

5

4

3

2

1

## REVISIONS

REV	DESCRIPTION	DWN	DATE
B	UPDATE DRAWING	KELLY	2018-03-14
C	UPDATE DRAWING	KELLY	2018-03-31

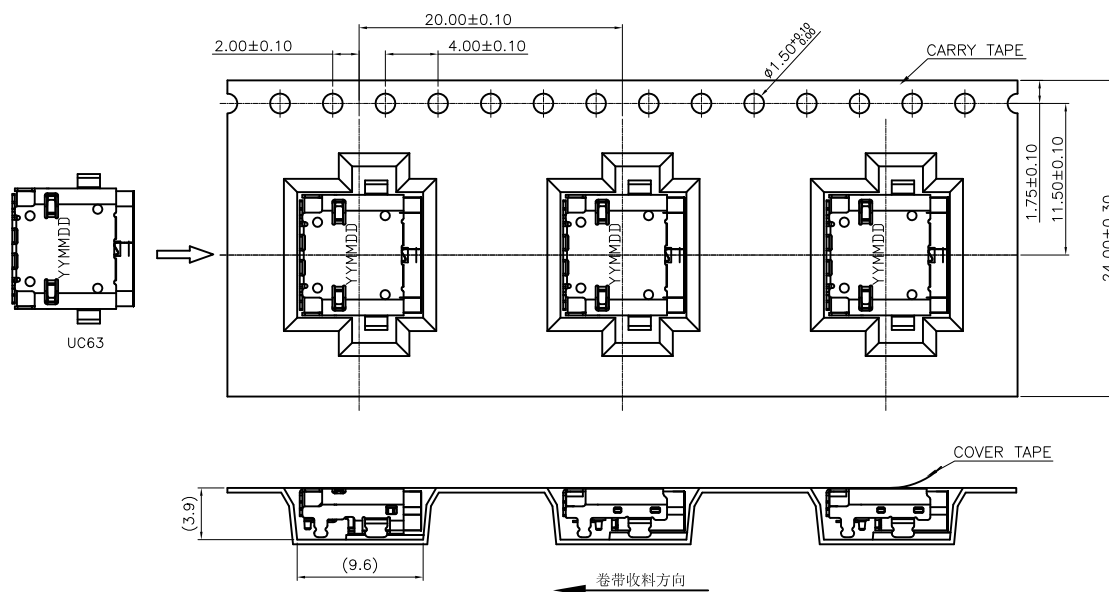
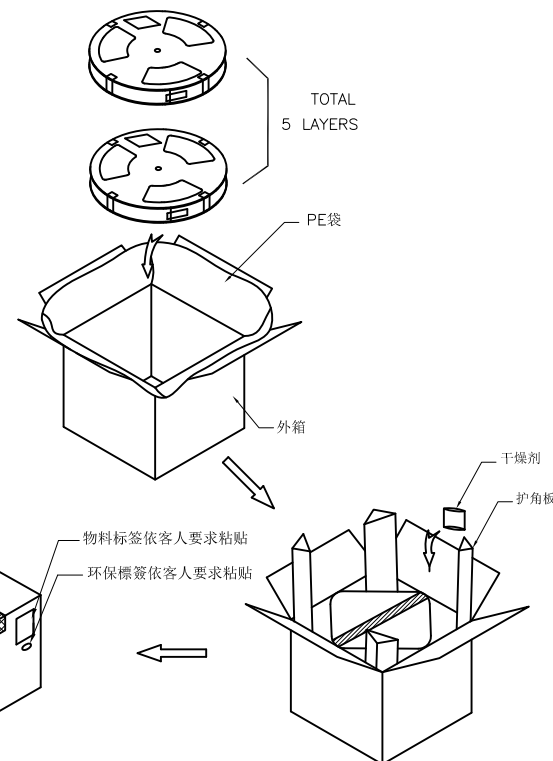
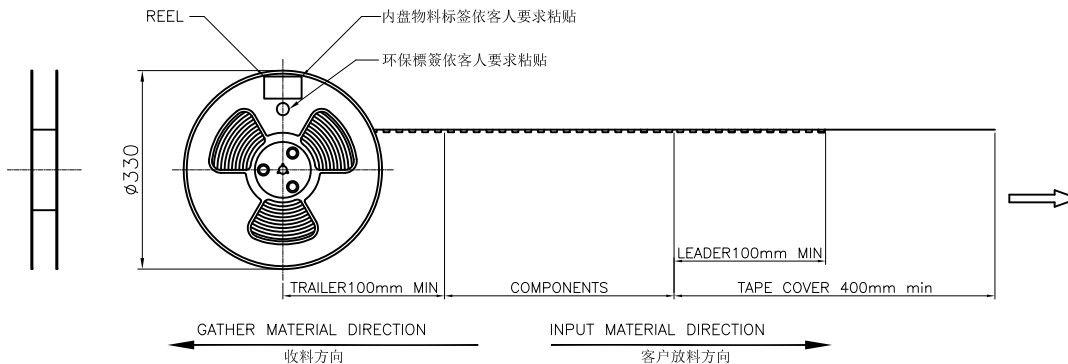

PARTS PER SHIPPING CARTON	PARTS PER REEL (S.P.Q.)	TOTAL REELS PER PRIMARY CARTON
3500 (PCS)	700 (PCS)	5

## Notes:

- 每卷卷带的开始端留160mm以上空格不装产品(参考值: 30PCS), 以实际包装数量装满后, 结束端预留160mm以上空格不装产品(参考值: 30PCS)
- 卷带用自封胶袋封口, 1个卷盘放置700PCS产品;
- 再绕一圈保护带, 保护带最后重量约50mm, 每个外箱外侧标签依客人要求粘贴;
- 将PE袋套入外箱后, 将5盘装好产品的卷盘依次放入纸箱, 并在纸箱封角各放入干燥剂一袋;
- 外箱外侧以胶袋封口, 每个外箱外侧标签依客人要求粘贴;
- COVER TAPE与CARRY TAPE剥离力: 20g~120g; 剥离角度: 165°~175°; 剥离速度: 250~300mm/min;
- 包装数量: 700PCS/REEL, 5REEL/CARTON, 共3500PCS/CARTON;
- 此部品必须符合《环境管理物质管控标准》要求。

GENERAL TOLERANCES (OTHERWISE SPECIFIED)		SCALE	DESIGN UNITS	
mm		NONE	MILIMETER	
4 PLS ±		DRAWN BY	DATE	TITLE USB TYPE C R/A DUAL-ROW SMT TYPE CH=0.85mm H=2.53mm
3 PLS ± 0.10		KELLY	2018-03-31	
2 PLS ± 0.20		CHECKED BY	DATE	
1 PLS ± 0.30		APPROVED BY	DATE	PART NO. UTC-011 SERIES
ANGLES ± °		DRAWING NO.	PK-UTC011-001	
QUALITY SYMBOLS	$\nabla=0$	THIS DRAWING CONTAINS INFORMATION THAT IS PROPRIETARY TO VITECK CORP., LTD AND SHOULD NOT BE USED WITHOUT WRITTEN PERMISSION		THIRD ANGLE PROJECTION
				DWG REV. C
				SHEET NO. 1 OF 1
				SIZE

7

6

5

4

3

2

1